



**BINE**

Information Service

projektinfo 09/03

## Geothermal Electricity Generation in Neustadt-Glewe

Fig 1



- ▶ **Combined heat and power (CHP) enhances energy use from geothermal resources**
- ▶ **Electricity can be generated from temperatures between 100 °C and 200 °C**
- ▶ **Geothermal energy is an ideal source for base load power**
- ▶ **Geothermal electricity production has great technical potential in Germany - the only restricting factor being the demand for heat**

*Geothermal heating plant in Neustadt-Glewe (Germany), where geothermal electricity production will start in November 2003*

In various geological regions of Germany, warm water (thermal waters) can be found at depths of between 1,000 and 5,000 m below the surface. Depending on region and depth, temperatures can range between 40 °C and 190 °C. Thermal waters in northern Germany and in the Rhine valley are highly saline, while those in the south are usually top drinking water quality. Germany currently has 24 large hydrothermal heating plants with outputs between 100 kW and 20 MW. The geothermal heat in these plants is often used in cascade form, e.g. heat recovery from thermal waters for district heating and subsequently for drinking water supply. Year-round availability of geothermal energy resources cannot be fully exploited for heat recovery because the drop in demand for heat during the summer months cannot be compensated for by the demand for process heat. Geothermal electricity production during the summer is thus one variation of the system model.

Deep hydrothermal geothermy goes back some 20 years in Germany. Between 1980 and 1990, hydrothermal heating plants went into operation in the towns of Waren, Neubrandenburg and Prenzlau in former East Germany, and other sites were assessed for their suitability. The facilities in Neubrandenburg and Waren were modernised following

German reunification. In Neustadt-Glewe (near Schwerin), a new facility model was developed and put into operation in 1995. Neustadt-Glewe has since supplied around 11 MW<sub>therm</sub> to a district heating net, 4.5 MW of which is geothermal. The facility was expanded to include electricity generation and was the site of Germany's first geothermal electricity production in November 2003.

As part of the German government's Zukunftsinvestitionsprogramm (invest in the future) scheme, the Federal Environment Ministry (BMU) has funded research and development projects in the amount of EUR 67 million. These projects include geothermal energy production, construction of research platforms, environmental studies on offshore wind farms, solar-thermal power plants, fuel production from renewable resources, and environmental studies on biomass use and fuel cells. Some EUR 21 million went to geothermal energy. Also included were projects on hot-dry rock processes in Bad Urach (Schwäbische Alb) and Groß Schönebeck (Brandenburg), and the joint EU project in Soultz-sous-Forêts (Alsace, France). The hydrothermal facilities funded under the scheme are representative of the differing geological conditions: Neustadt-Glewe (North-East Germany), Unterhaching (South Germany) and Offenbach (South West Germany).

## ► Process

In the North German basin, large reserves of thermal water can be found in porous sandstone deposits at a depth of between 1.5 - 2.5 km. Depending on depth and layer, salinity can range between 80 and 350 g/l (by way of comparison, sea water has an average 35 g/l salinity). This salinity level

requires that facilities be particularly resistant to corrosion.

To exploit energy from such highly saline geothermal water, two bore holes are drilled into the layer containing the water (Fig. 2): an extraction bore hole and an injection bore hole about 1.5 - 2 km further away. An immersion pump pumps the warm water from the extraction probe into the over-ground thermal water system. A heat exchanger then extracts heat from the salty thermal water and feeds it into the district heat net. An integrated ORC turbine is used to recover excess heat for electricity production in times of low demand for heat from the district heat net. Integrating a heat pump into the system could make better use of the heat available. In Neustadt-Glewe, however, preference was given to direct heat use. The cooled

**Fig 2: Schematic Diagram of Geothermal Energy Use in Neustadt-Glewe with an ORC Turbine**

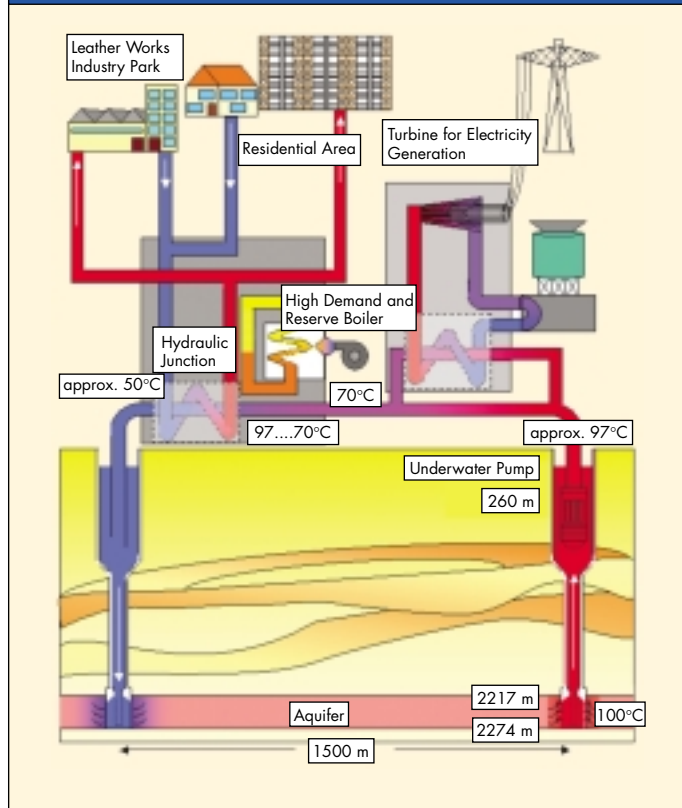

**Fig 3: Regions of Germany with Deep Geothermal Resources**

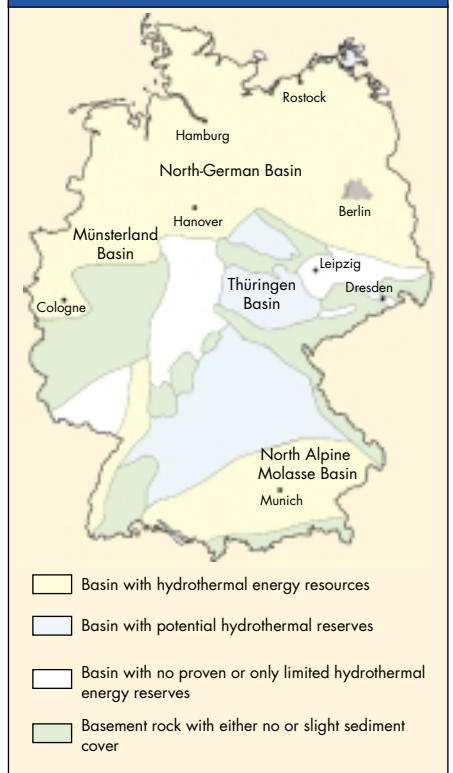

thermal water is injected back into the ground it was extracted from through the injection bore hole. Geothermal systems are designed to operate for at least 30 years without any noteworthy reduction in thermal water temperature.

## ► Geothermal Heating Plants in Operation

The geothermal heating plant in Neustadt-Glewe has been in operation since 1995. One important argument in favour of this site was the high aquifer temperature of 100 °C compared with that at Waren and Neubrandenburg. Between 40 and 120 m<sup>3</sup> (11-33 l/sec.) are extracted every hour. The salinity of the water is 220 g/l. The glassfibre reinforced epoxy resin pipes showed no evidence of corrosion. After heat recovery, the water is reinjected into the original rock layer at a temperature of 50 °C.

Up to now, the geothermal heat has supplied a modernised district heating net (see Fig. 4) and has a peak output of 11 MW<sub>therm</sub>, of which 4.5 MW<sub>therm</sub> is geothermal. A boiler has been integrated to cope with peak demand on cold winter days. So far, the system has supplied an annual average of 90 - 95 per cent of heat demand from geothermal energy. Because of the high temperature of the thermal water, the heating

**Fig 4: Statistics for the System at Neustadt-Glewe and Selected Geothermal Heating Plants**

	Neustadt-Glewe	Waren	Erding	Straubing
Location	North Germany	North Germany	South Germany	South Germany
In Operation Since	1995	1984	1998	1999
Heat Supply - Total	23,700 MWh/a	10,150 MWh/a	49,000 MWh/a	19.2 MWh/a
- Geothermal	22,200 MWh/a	4,100 MWh/a	15,000 MWh/a	7 MWh/a
Homes Supplied	1,300 Homes, 21 Businesses, Leather Works	1,705 Homes		Public Building Thermal Baths
With Heat Pump	no	yes	yes	yes
Temperature of Extracted Water	95 - 98 °C	62 °C	65 °C	38 °C
producing Depth	2,250 m	1,565 m	2,350 m	825 m

plant operates solely in direct transfer, i.e. without an intermediate heat pump.

Fig. 5 shows the drop in heat demand during the summer months. This cannot be compensated for by supplying heat to industry. Geothermal potential thus

remains unexploited during the summer. This influences commercial viability, because up to 40 per cent of the costs involved in a geothermal system stem from drilling alone. At the Neustadt-Glewe facility, operational factors are also an issue. Nega-

**Fig 5: Monthly Fluctuation in Thermal Water Extraction in Neustadt-Glewe in Pure Heat Operation (Year 2000)**

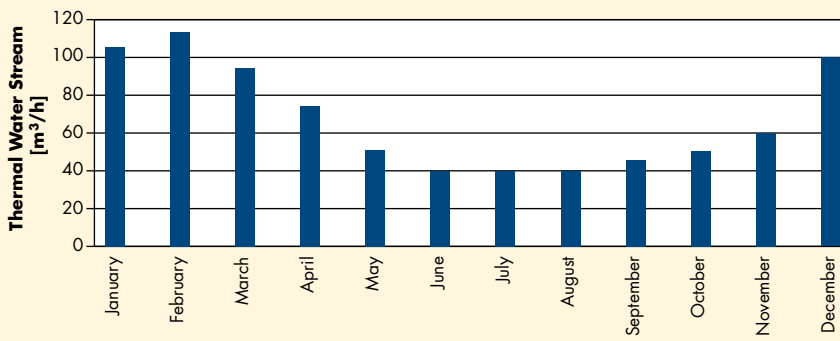

tive pressure (a partial vacuum) occurs at the injection bore hole as soon as the injection rate falls below 80 m³ per hour. This allows oxygen to enter the system in what is usually a closed thermal water cycle, causing the gases dissolved in the thermal water (proportion: approx. 10%) – largely carbon dioxide, nitrogen and methane – to vaporise off. This is why Neustadt-Glewe is particularly suited to geothermal electricity production.

## ► Geothermal Electricity Production

In contrast to heat, the demand for electricity is constant and year-round. The electricity generated in geothermal facilities can be fed into the grid at any time.

In Germany, temperatures in geological warm water reserves are at the very bottom end of the range used in electricity production. Conventional power station technology is not suited to electricity production from warm water with temperatures of between 80 and 190 °C. An ORC (organic Rankine cycle) heat generating system is usually needed. With an ORC, steam is fed through a turbine under high pressure and at high temperatures, where it expands and cools. The turbine powers an electricity generator. Compared with conventional steam turbine processes, an organic agent (e.g. n-pentane, isobutane) is used. The KALINA process provides an alternative to ORC and uses a mixture of ammoniac and water. Although still in the early phases of development, the KALINA process promises high electrical efficiency and low electricity production costs.

The achievable electrical efficiency with an ORC system is around 6.5 per cent at a temperature of 100 °C and between 13 - 14 per cent at 200 °C. An overall assessment must however take account of the fact that – in contrast to coal, oil and gas used in

power stations – the use of geothermal energy involves no fuel costs and its extraction is emission-free. If the heat is also used after electricity production, then total energy efficiency is even higher. It is currently thought that future projects involving

geothermal electricity production in Germany require a minimum temperature of 100 °C and a minimum flow rate of 50 m³/h. ORC turbines are now on the market with an output range of between 100 - 250 kW.

**Fig 6: Schematic Diagram and Operating Data for the Geothermal Heating Plant at Neustadt-Glewe**

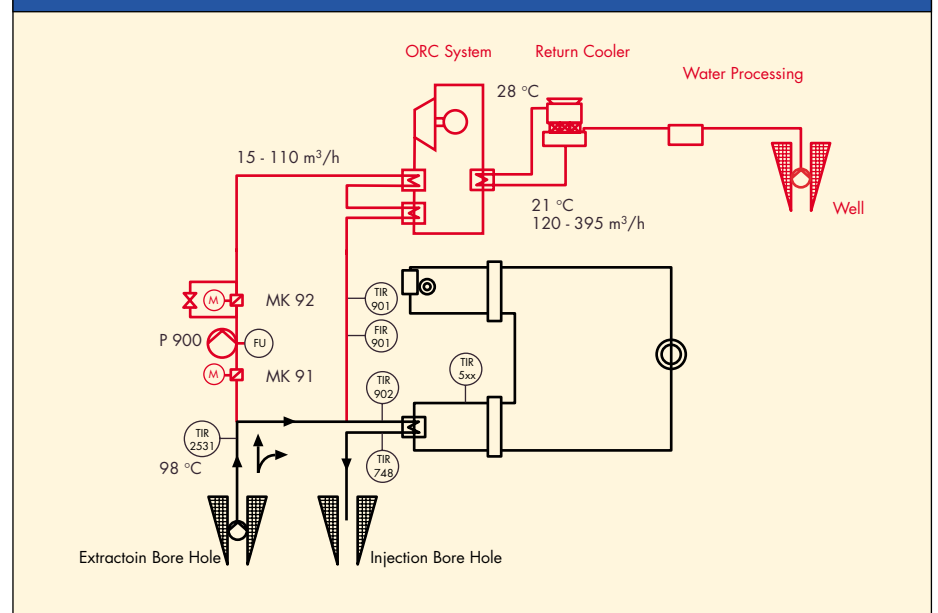

## ► ORC Facility in Neustadt-Glewe

**Fig 7: Electricity Potential from Hot Water Aquifers in Germany in several Temperature Classes**

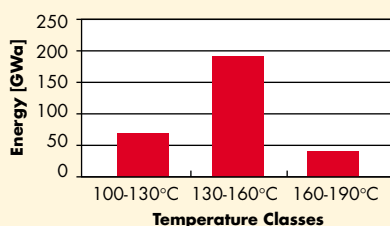

The facility at Neustadt-Glewe has an ORC which is integrated into the thermal water cycle directly behind the extraction bore hole. With an output of 210 kW, the facility produces around 1.2 million kWh of electricity per year. Some 500 households could be supplied with geothermal electricity in future. This prognosis assumes 90% availability of the geothermal system. The facility in Neustadt-Glewe has achieved this level constantly in recent years. One component of the future development process for system optimisation is a further increase in efficiency in

terms of the system's own electricity use. The ORC facility is operated by Erdwärme-Kraft GbR under a special contract. Following electricity generation, the water – which is still at 70 - 84 °C – is transferred to the districting heat net. The geothermal combined heat and power plant (CHP) is heat driven. Heat supply is the primary aim, with electricity production taking place at times when demand for heat is low. In the winter months, when demand for heat peaks, electricity production is closed down altogether for short periods.

## ► Outlook

The geothermic heating plant in Neustadt-Glewe is an important pilot project with which to gain experience in operating geothermal electricity production under the geological conditions specific to Germany. The high temperature level, the known flow rate, the excess heat in summer months, and its operation as a CHP, all make this facility suitable for integrated electricity production. Experience gathered at Neustadt-Glewe is useful for geothermal electricity production at other locations – both hydrothermal and hot-dry rock process.

Availability of geothermal electricity is independent of seasons and daylight and is thus suited to base load power supply. Germany's geothermal electricity potential is huge. With today's technologies, the available potential is equal to about 600 times Germany's annual electricity consumption. Only 1% is apportioned to hot-water aquifers. But even this is still five times higher than current annual electricity consumption. This technical potential cannot be realised because the demand for heat is the limiting factor. If all German district heating nets were supplied with geothermal heat only, then the proportion of geothermal electricity would amount to 2% of Germany's electricity use. To further increase the share of geothermal electricity, these heat nets and other sources of demand for heat must be further developed.

**Fig 8: Technical Details of Further Projects on Geothermal Electricity Production (funded by the ZIP Programme)**

Location	Drill Holes	Depth [m]	Temperature [°C]	Extraction Volume [m <sup>3</sup> /h]	Electricity Output [MW]
Bad Urach	Target: 4 Current: 3	4.450	170	180	1
Unterhaching	2	3.100	120	540	0,54
Offenbach/Pfalz	2	2.500	150	360	6,5
Groß-Schönebeck	Target: 2 Current: 1	4.300	140	Target: 75 Current: 25	0,8
Soultz-sous-Forêts	4	5.000	200	360	6
Bruchsal	2	2.540	135	50	0,24

At present, geothermal electricity is still relatively expensive. The possible electricity generation costs depend i.a. on the drilling depth, the temperature at that depth, the electricity consumption of the installation itself and the extraction volumes. Current calculations indicate that the kilowatt hour of geothermal electricity would cost around 18-22 cents. However, if we take the geological conditions of Oberrheingrabens as a basis and assume a temperature of 180° C and an extraction rate of 200 m<sup>3</sup>/h, electricity generation costs of 8 cents are possible. On the technical side, improved efficiency in drilling technology and electricity generation installations can be expected, leading to lower costs.

## PROJECT ORGANISATION

### ■ Project Funding

Federal Ministry for Environment, Nature Conservation and Nuclear Safety (BMU)  
Postfach 12 06 29  
53408 Bonn, Germany

Project Coordination on behalf of the  
BMWA and BMU  
Research Centre Jülich  
Project Management Organisation Jülich  
Dr. Dieter Rathjen  
52425 Jülich, Germany

### ■ Project number

0327094, 0327509

## IMPRINT

### ■ ISSN

0937 – 8367

### ■ Publisher

FIZ Karlsruhe  
76344 Eggenstein-Leopoldshafen, Germany

### ■ Reprint

Reproduction of this text is permitted provided the source is quoted and a complimentary copy is provided to the publisher; reproduction of the images contained in this newsletter requires the prior approval of the copyright owner.

### ■ Editor

Uwe Milles

## BINE Information Service Energy Expertise

BINE provides information on energy efficient technologies and renewable energy:

Using a combination of free brochures, the BINE web site ([www.bine.info](http://www.bine.info)) and a newsletter, BINE shows how innovative research ideas hold up in practice (in german).

The BINE information service is promoted by the Federal Ministry of Economics and Labour (BMWA).

### Contact:

Would you like to know more about this project?

Call the BINE expert hotline at:

Tel. +49 228 92379-44

For more general information on energy and environmentally sound planning and construction, please contact us at:

 **BINE**  
Information Service

FIZ Karlsruhe  
Bonn Office  
Mechenstrasse 57  
53129 Bonn  
Germany

Tel.: +49 228 92379-0  
Fax: +49 228 92379-29  
E-mail: [bine@fiz-karlsruhe.de](mailto:bine@fiz-karlsruhe.de)  
[www.bine.info](http://www.bine.info)

## ► PROJECT ADDRESSES

- Erdwärme Kraft GbR.  
Marc Koch, Dr. Heiner Menzel  
Köpenicker Str. 59 - 71  
10179 Berlin  
Germany

## ► ADDITIONAL INFORMATION

### Literature

- Federal Ministry for Environment, Nature Conservation and Nuclear Safety (Eds.), Fachtagung „Geothermische Stromerzeugung – eine Investition in die Zukunft“ am 20./21. Juni 2002 in Landau/Pfalz. Tagungsband. Download: [http://www.bmu.de/files/tagungsband\\_geothermie.pdf](http://www.bmu.de/files/tagungsband_geothermie.pdf) [In German only]
- Paschen, H.; Oertel, D.; Grünwald, R.; Möglichkeiten geothermischer Stromerzeugung in Deutschland. Deutsche Bundestag – Ausschuss für Bildung, Forschung und Technologiefolgenabschätzung, TAB-Arbeitsbericht Nr. 84, Februar 2003. Available for download on the BINE web site under Service/InfoPlus.